



**SUNCOMBE**  
CIP & PROCESS ENGINEERS



**Gillain & Co**  
HYGIENIC EQUIPMENT FOR FOOD & LIFE SCIENCES

**SaniTank™**



## About Us

Suncombe Limited is an organization dedicated to the advancement of and Hygienic processing and cleaning technology. We design and manufactures high quality, economically priced tanks, vessels, mixers and processors from 10 litre capacity. We have been supplying these for over 45 years, where they have established a reputation for high quality and longevity.

## Introduction

The Suncombe **SaniTank™** is a range of fully sanitary atmospheric tanks, available in a range of standard sizes from 10—350 litre with the option of custom design and manufacture for your particular requirement.

## Equipment Standards

Built from 316L stainless steel internally with 304/316 external fitments. Fully sanitary, the base internal finish is 180 grit, with higher finishes on demand including 0.4  $\mu\text{mRa}$  surface finishes, 0.1  $\mu\text{mRa}$  and electropolished finishes available.

## Documentaion Package

2.2b Certificate of Conformity, construction drawings, maintenance procedures, datapack. Options for Materials of construction certificates (3.1b's), Weld Procedures, Welder Approval Certificates, Isometric Weld Log Drawings, engraved welds. Full validation data Dossier.

## Typical uses

Used in all processing industries for sanitary storage, processing and mixing. Typical uses include::

- » Mix Tanks and Base Tanks
- » Batch Processors, Pasteurizers and Holding Tanks
- » Balance Tanks, CIP Tanks, Sterile Solution Tanks
- » Media Processors, Harvest Tanks and Reactors
- » Storage, Bio Reactors and Solution Preparation
- » Hold Tanks, Transfer Tanks, Pilot Plant Tanks

## Details

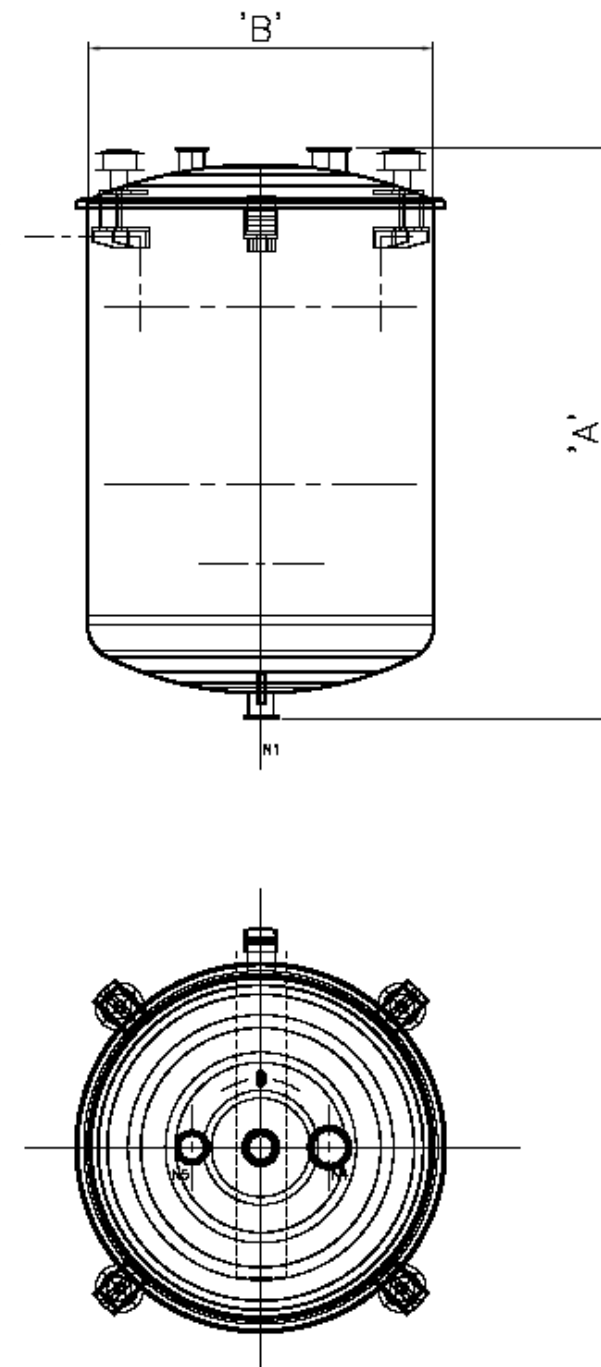

## Options

The tanks are available as static or mobile tanks with castors. Equipment can be added to the tanks. Typical equipment additions include sprayballs, valves, sightglasses, level probes, heaters, coolers, pumps, load cells and lid switches.

## Skid Mounted

The tanks can also be built into custom processing skids to fulfil any processing requirement.

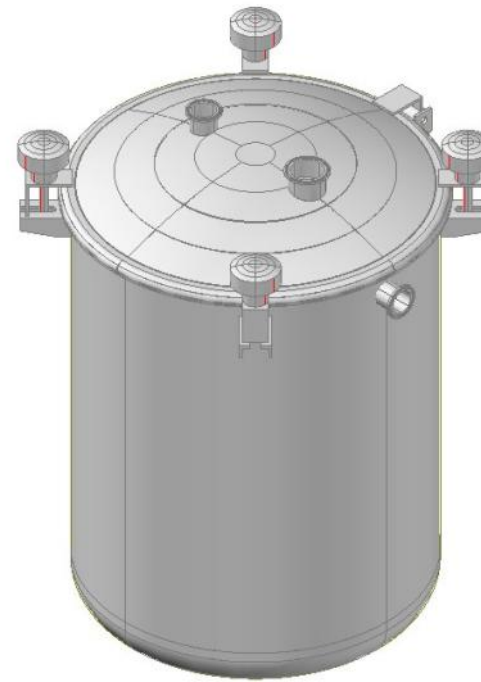

Capacity litres	Height (A) mm	Diameter (D) mm
10	300	205
20	300	305
30	420	305
40	550	305
50	400	425
75	550	425
100	700	425
125	600	465
150	750	505
175	850	505
200	700	605
250	850	605
300	750	706
350	900	706
400	800	806



Typical Skid Mounted SaniTank™

## Cleanability

Suncombe **SaniTank™** can be supplied with a computer generated simulation of the cleaning pattern for the internals of the vessel. This graphic gives confirmation of the cleanability of the vessels and can be used for validation purposes. Together with standard ribo-flavin tests at Factory Acceptance Testing.

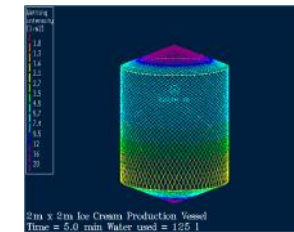

Spray Pattern Graphic

## Complimentary Cleaning Systems

Suncombe manufacture a range of Cleaning systems that are designed to clean these vessels.

## Integrated Systems

**SaniTank™** can be integrated into a complete process system including process evaluation, P&ID development, Plant layout, Detail design, equipment construction, procurement of ancillaries, Installation/commissioning, documentation and validation and training.

## Standard Features

- 20 to 350 litre vessels
- Atmospheric design
- 316L Stainless Steel Construction
- Various Internal Surface Finish
- Stainless Steel polished Framework
- Drainable, crevice free design
- Data Dossier
- Bottom triclamp Outlet, two top triclamp inlets