



First ever EHEDG certified Tank Cleaning Machine

Toftejorg SaniJet 25 Rotary Jet Head

Application

The Toftejorg SaniJet 25 rotary jet head provides 3D indexed impact cleaning over a defined time period. It is automatic and represents a guaranteed means of achieving quality assurance in tank cleaning. Used in food and dairy processes, pharmaceutical and biotechnology industries, the device is suitable for processing, mixing and storage tanks/vessels between 15 and 150 m³. The design is particularly suitable for ultra-hygienic industries that follow European Hygienic Engineering & Design Group Guidelines.

Working principle

The flow of the cleaning fluid makes the nozzles perform a geared rotation around the vertical and horizontal axes. In the first cycle, the nozzles lay out a coarse pattern on the tank surface. The subsequent cycles gradually make the pattern more dense, until a full pattern is reached after 8 cycles.



TECHNICAL DATA

Lubricant: Self-lubricating with the cleaning fluid
Standard Surface finish: Ra 0.5µm exterior / Ra 0.8µm internal
Max throw length: 9 - 14 m
Impact throw length: 4 - 8 m

Pressure

Working pressure: 3 - 8 bar
Recommended pressure: 5 - 6.5 bar

Cleaning Pattern

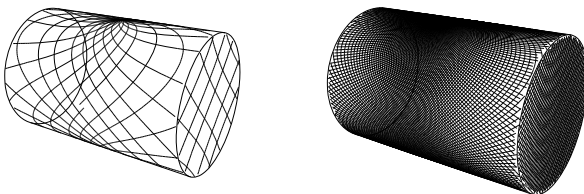

First cycle

Full pattern

The above drawings show the cleaning pattern achieved on a cylindrical horizontal vessel. The difference between the first cycle and the full pattern represents the number of additional cycles available to increase the density of the cleaning.

Certificates

2.2 material certificate, Q-doc, Q-doc incl. FAT & SAT, ATEX and EHEDG.

PHYSICAL DATA

Materials

316L (UNS S31603), Duplex steel (UNS N31803), Duplex steel (UNS S21800), PEEK*, PFA* and EPDM*

* FDA compliance 21CFR§177

Welding connection

1" ISO, 1" ANSI/Sch40, 1½" BPE US/SWG, 1½"Dairy, 1½"ANSI/Sch40 or NW40.

Temperature

Max. working temperature: 95°C
Max. ambient temperature: 140°C

Weight: 5.1 kg

Options

Electronic rotation sensor to verify 3D coverage. Declaration of Conformity with ATEX Directive 94/9/EC ATEX approved, Category 1 for installation in zone 0/20.

Caution

Avoid hard and abrasive particles in the cleaning liquid, as this will cause increased wear and/or damage of internal mechanisms. It is recommended to install a filter in the supply line.

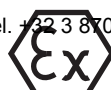

Standard Design

The choice of nozzle diameters can optimize jet impact length and flow rate at the desired pressure. To maintain the hygienic state of the machine a welding adaptor matching a specific pipe size comes with the machine together with the necessary gaskets. The Toftejorg SaniJet 25 is designed, tested and approved according to EHEDG guidelines on design (guidelines 8), cleanability (guidelines 2) and in-line steam sterilisability (guidelines 5). As standard documentation, it is supplied with a "Declaration of Conformity" for material specifications and surface roughness according to EN 10204 type 2.1 and 2.2.

Qualification Documentation (Q-doc)

Designed for the BioPharm and Personal Care industry for qualification of hygienic Tank Cleaning Machines. Developed in accordance to the ISPE V-model and GDP, Good Documentation Practice, and includes: RS (Requirement Specification); DS (Design Specification incl. Traceability Matrix); FAT (Factory Acceptance Test incl. IQ & OQ); 3.1 and USP Class VI Certificates; FDA Declaration of Conformity; TSE Declaration; QC Declaration of Conformity; SAT (Site Acceptance Test Protocol incl. IQ & OQ for End-User Execution).

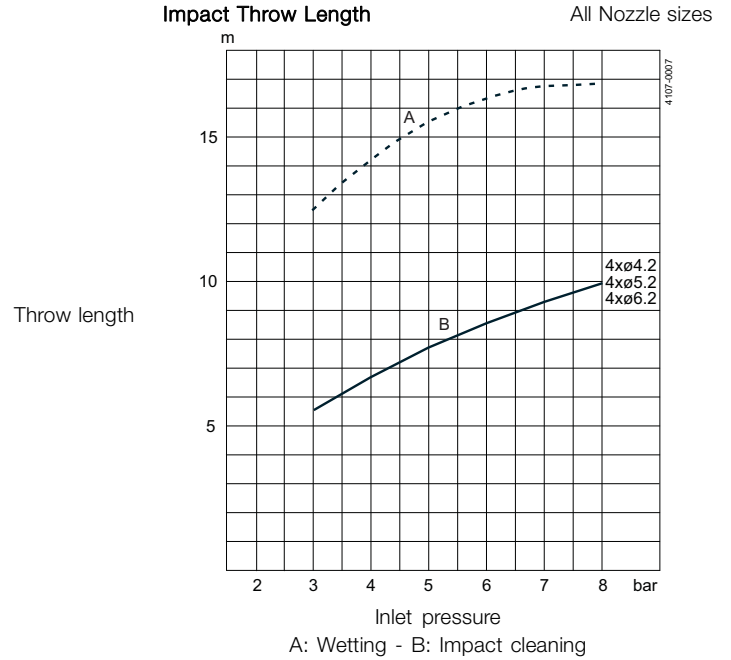
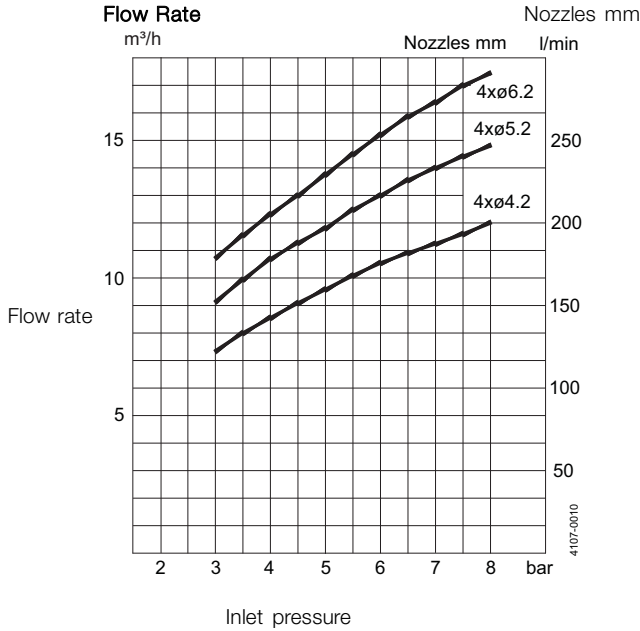

Dimensions (mm)

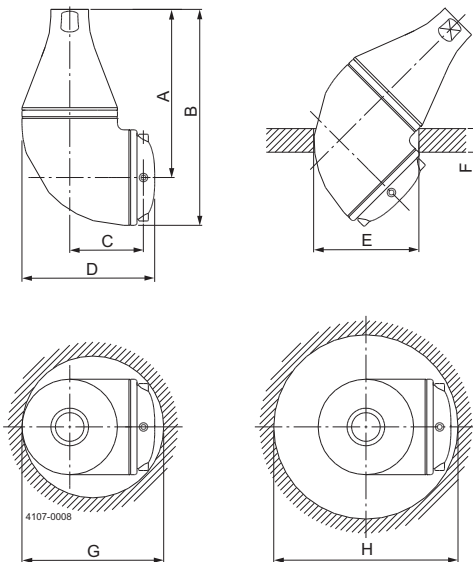

Cleaning Time, Complete Pattern

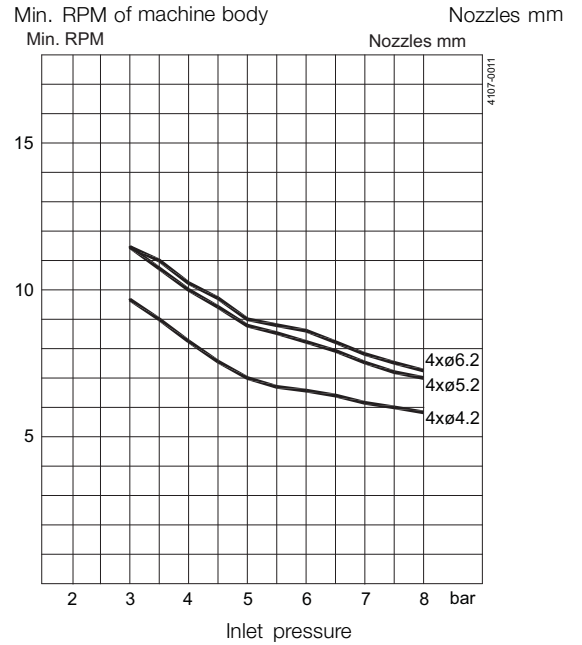

| A | B | C | D | E | F | G | H |
|-----|-------|----|-----|------|---------|------|------|
| 178 | 228.5 | 80 | 140 | ø110 | max. 25 | ø150 | ø195 |

Alfa Laval reserves the right to change specifications without prior notification. ALFA LAVAL is a trademark registered and owned by Alfa Laval Corporate AB.

ESE00311EN 1201

© Alfa Laval

How to contact Alfa Laval

Contact details for all countries are continually updated on our website. Please visit www.alfalaval.com to access the information direct.

Gillain & Co NV | Boomsesteenweg 85, B-2630 Aartselaar | Tel. +32 3 870 60 80, Fax +32 3 870 60 89 | advice@gillain.com | www.gillain.com