

10

Bouten / Moeren

Boulons / Ecrous

Schrauben / Muttern

Bolts / Nuts

SLUITRING ZONDER AFSCHUINING
RONDELLE PLATE SANS CHANFREIN
 UNTERLEGSCHIEBEN OHNE FASE
WASHER WITHOUT FACET

DIN 125-A
DIN 125-A
 DIN 125-A
DIN 125-A

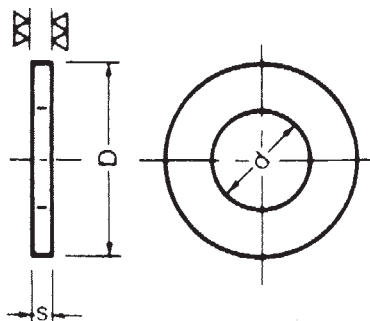

| | | |
|--------------|-------------------|--------------------|
| AISI | 304 | 316 |
| W.Nr. | 1.4301(A2) | 1.4401 (A4) |

| | d | D | S | kg/1000 st. kg/1000 pces |
|--|-------|-------|------|-----------------------------|
| Voor schroef Pour vis Für Schraube For bolt | | | | |
| M 3..... | 3,20 | 7,00 | 0,50 | 0,120 |
| M 4..... | 4,30 | 9,00 | 0,80 | 0,308 |
| M 5..... | 5,30 | 10,00 | 1,00 | 0,443 |
| M 6..... | 6,40 | 12,50 | 1,60 | 1,14 |
| M 7..... | 7,40 | 14,00 | 1,60 | 1,39 |
| M 8..... | 8,40 | 17,00 | 1,60 | 2,14 |
| M10..... | 10,50 | 21,00 | 2,00 | 4,08 |
| M12..... | 13,00 | 24,00 | 2,50 | 6,27 |
| M14..... | 15,00 | 28,00 | 2,50 | 8,60 |
| M16..... | 17,00 | 30,00 | 3,00 | 11,30 |
| M18..... | 19,00 | 34,00 | 3,00 | 14,70 |
| M20..... | 21,00 | 37,00 | 3,00 | 17,20 |
| M22..... | 23,00 | 39,00 | 3,00 | 18,40 |
| M24..... | 25,00 | 44,00 | 4,00 | 32,30 |

All models, types, values, rates, dimensions, a.s.o. are subject to change, without notice

10

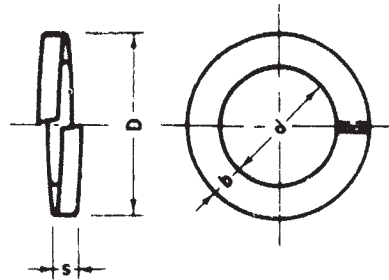

| | | |
|--------------|-------------------|--------------------|
| AISI | 304 | 316 |
| W.Nr. | 1.4301(A2) | 1.4401 (A4) |

| | d | D | h | | S | kg/1000 st. kg/1000 pces |
|--|------------|------------|------------|------------|-----------|-----------------------------|
| | | | min. | max. | | |
| Voor schroef Pour vis Für Schraube For bolt | | | | | | |
| M3..... | 3,10..... | 6,20..... | 1,60..... | 1,90..... | 0,80..... | 0,112 |
| M4..... | 4,10..... | 7,60..... | 1,80..... | 2,10..... | 0,90..... | 0,18 |
| M5..... | 5,10..... | 9,20..... | 2,40..... | 2,80..... | 1,20..... | 0,36 |
| M6..... | 6,10..... | 11,80..... | 3,20..... | 3,80..... | 1,60..... | 0,83 |
| M8..... | 8,10..... | 14,80..... | 4,00..... | 4,70..... | 2,00..... | 1,60 |
| M10..... | 10,20..... | 18,10..... | 4,40..... | 5,20..... | 2,20..... | 2,53 |
| M12..... | 12,20..... | 21,10..... | 5,00..... | 5,90..... | 2,50..... | 3,82 |
| M14..... | 14,20..... | 24,10..... | 6,00..... | 7,10..... | 3,00..... | 6,01 |
| M16..... | 16,20..... | 27,40..... | 7,00..... | 8,30..... | 3,50..... | 8,91 |
| M18..... | 18,20..... | 29,40..... | 7,00..... | 8,30..... | 3,50..... | 9,73 |
| M20..... | 20,20..... | 33,60..... | 8,00..... | 9,40..... | 4,00..... | 15,20 |
| M22..... | 22,20..... | 35,90..... | 8,00..... | 9,40..... | 4,00..... | 16,50 |
| M24..... | 24,50..... | 40,00..... | 10,00..... | 11,80..... | 5,00..... | 26,20 |
| M27..... | 27,50..... | 43,00..... | 10,00..... | 11,80..... | 5,00..... | 28,70 |
| M30..... | 30,50..... | 48,20..... | 12,00..... | 14,20..... | 6,00..... | 44,30 |

All models, types, values, rates, dimensions, a.s.o. are subject to change, without notice

10

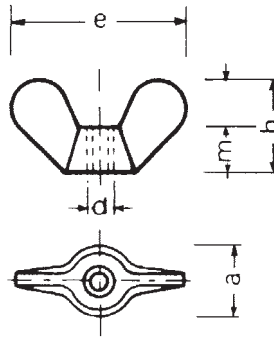

| AISI | 304 | 316 |
|-------|------------|-------------|
| W.Nr. | 1.4301(A2) | 1.4401 (A4) |

| d | a | e | h | m | kg/1000 st. kg/1000 pces |
|-----|----|-----|----|----|-----------------------------|
| M3 | 8 | 20 | 10 | 4 | 2 |
| M4 | 8 | 20 | 10 | 5 | 2 |
| M5 | 10 | 25 | 12 | 6 | 4 |
| M6 | 12 | 32 | 16 | 8 | 8 |
| M8 | 16 | 40 | 20 | 10 | 17 |
| M10 | 20 | 50 | 25 | 12 | 35 |
| M12 | 23 | 64 | 32 | 14 | 60 |
| M14 | 23 | 64 | 32 | 14 | 60 |
| M16 | 28 | 72 | 36 | 16 | 90 |
| M18 | 28 | 72 | 36 | 16 | 90 |
| M20 | 36 | 90 | 45 | 20 | 180 |
| M22 | 36 | 90 | 45 | 20 | 180 |
| M24 | 36 | 112 | 56 | 24 | 260 |

All models, types, values, rates, dimensions, a.s.o. are subject to change, without notice

BINNENZESKANTSCHROEVEN MET CYLINDERKOP
VIS A TETE CYLINDRIQUE, SIX PANS
ZYLINDERSCHRAUBEN MIT INNENSECHSKANT
HEXAGON SOCKET HEAD CAP SCREW

DIN 912
DIN 912
DIN 912
DIN 912

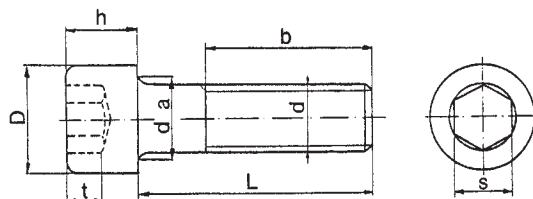

| | | |
|--------------|-------------------|--------------------|
| AISI | 304 | 316 |
| W.Nr. | 1.4301(A2) | 1.4401 (A4) |

| | | | | | | | | | |
|---------|-------|-------|-------|-------|-------|-------|-------|-------|-------|
| d..... | M3 | M4 | M5 | M6 | M8 | M10 | M12 | M16 | M20 |
| D..... | 5,50 | 7,00 | 8,50 | 10,00 | 13,00 | 16,00 | 18,00 | 24,00 | 30,00 |
| h..... | 3,00 | 4,00 | 5,00 | 6,00 | 8,00 | 10,00 | 12,00 | 16,00 | 20,00 |
| da..... | 3,60 | 4,70 | 5,70 | 6,80 | 9,20 | 11,20 | 14,20 | 18,20 | 22,40 |
| b..... | 18,00 | 20,00 | 22,00 | 24,00 | 28,00 | 32,00 | 36,00 | 44,00 | 52,00 |
| S..... | 2,50 | 3,00 | 4,00 | 5,00 | 6,00 | 8,00 | 10,00 | 14,00 | 17,00 |
| t..... | 1,30 | 2,00 | 2,50 | 3,00 | 4,00 | 5,00 | 6,00 | 8,00 | 10,00 |

| | |
|---|--------------|
| | kg/1000 st. |
| L | kg/1000 pces |

| | | | | | | | | | |
|----------|------|------|-------|-------|-------|-------|-------|--------|--------|
| 8..... | 0,80 | 1,65 | | | | | | | |
| 10..... | 0,88 | 1,80 | 2,70 | 4,70 | | | | | |
| 12..... | 0,96 | 1,95 | 2,95 | 5,07 | | | | | |
| 16..... | 1,16 | 2,25 | 3,45 | 5,75 | 12,10 | 20,90 | | | |
| 20..... | 1,36 | 2,65 | 4,01 | 6,53 | 13,40 | 22,90 | 32,10 | | |
| 25..... | 1,61 | 3,15 | 4,78 | 7,59 | 15,00 | 25,40 | 35,70 | | |
| 30..... | 1,86 | 3,65 | 5,55 | 8,30 | 16,90 | 27,90 | 39,30 | 77,80 | |
| 35..... | 2,11 | 4,15 | 6,32 | 9,91 | 18,90 | 30,40 | 42,90 | 84,40 | |
| 40..... | | 4,65 | 7,09 | 11,00 | 20,90 | 32,90 | 46,50 | 91,00 | 150,00 |
| 45..... | | 5,15 | 7,86 | 12,10 | 22,90 | 36,10 | 50,10 | 97,60 | 161,00 |
| 50..... | | 5,65 | 8,63 | 13,20 | 24,90 | 39,30 | 54,50 | 106,00 | 172,00 |
| 60..... | | | 10,20 | 15,40 | 28,90 | 45,70 | 63,40 | 122,00 | 194,00 |
| 70..... | | | | | 33,00 | 52,10 | 71,30 | 138,00 | 216,00 |
| 80..... | | | | | 37,00 | 58,50 | 80,20 | 154,00 | 241,00 |
| 90..... | | | | | 41,00 | 64,90 | 89,10 | 170,00 | 266,00 |
| 100..... | | | | | 45,00 | 71,20 | 98,00 | 186,00 | 291,00 |

All models, types, values, rates, dimensions, a.s.o. are subject to change, without notice

10

STELSCHROEF ZONDER KOP, BINNENZESKANT, HOLLE PUNT
VIS SANS TETE, SIX PANS, POINTE CREUSE
 GEWINDESTIFTE MIT INNENSECHSKANT
HEADLESS HEXAGON SCREW

DIN 916
DIN 916
 DIN 916
DIN 916

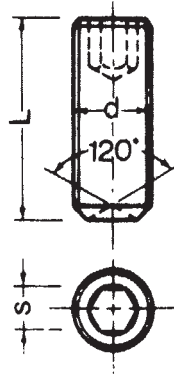

| | | |
|--------------|-------------------|--------------------|
| AISI | 304 | 316 |
| W.Nr. | 1.4301(A2) | 1.4401 (A4) |

d.....M3M4.....M5.....M6M8.....M10.....M12.....M16.....M20.....M24
 S.....1,502,00.....2,50.....3,004,005,00.....6,008,00.....10,0012,00

| | |
|--|---------------|
| | kg./1000 st. |
| L | kg./1000 pces |
| 4.....0,140,30 | |
| 5.....0,180,36.....0,52 | |
| 6.....0,220,38.....0,54.....0,85 | |
| 8.....0,310,53.....0,78.....1,09 | |
| 10.....0,400,68.....1,02.....1,442,51 | |
| 12.....0,490,83.....1,26.....1,793,144,73 | |
| 16.....0,671,13.....1,74.....2,494,406,73.....9,50 | |
| 20.....0,851,43.....2,22.....3,195,66.....8,71.....12,3020,90 | |
| 25.....2,82.....4,077,25.....11,20.....15,9027,40.....41,40 | |
| 30.....3,40.....4,958,84.....13,70.....19,5034,00.....51,7070,30 | |
| 35.....5,8310,4016,20.....23,1040,50.....62,0085,30 | |
| 40.....6,8012,0018,70.....26,7047,10.....72,30100,00 | |
| 45.....7,9013,6021,40.....30,2053,70.....82,60115,00 | |
| 50.....8,0015,20.....24,00.....33,7060,50.....92,90130,00 | |
| 55.....37,2067,00.....103,00145,00 | |
| 60.....41,0073,50.....114,00160,00 | |

All models, types, values, rates, dimensions, a.s.o. are subject to change, without notice

ZESKANTSBOUT MET GEDEELTELIJKE DRAAD
VIS À TÊTE HEXAGONALE AVEC FILET PARTIEL
 SECHSKANTSCHRAUBEN MIT TEILGEWINDE
HEXAGON HEADED BOLT PARTIAL THREADED

DIN 931
DIN 931
 DIN 931
DIN 931

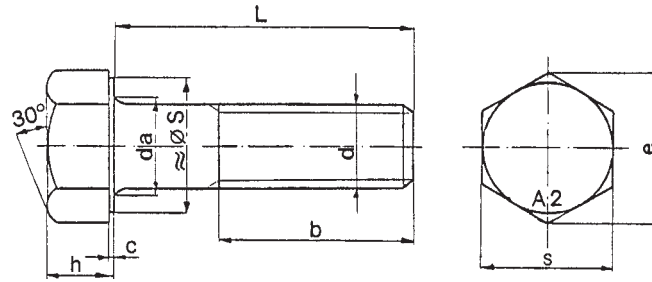

| | | |
|--------------|-------------------|--------------------|
| AISI | 304 | 316 |
| W.Nr. | 1.4301(A2) | 1.4401 (A4) |

| | | | | | | | | | | |
|---------|------------|------------|------------|------------|------------|------------|------------|------------|------------|-------|
| d..... | M5..... | M6..... | M8..... | M10..... | M12..... | (M14)..... | M16..... | (M18)..... | M20..... | M24 |
| da..... | 5,70..... | 6,80..... | 9,20..... | 11,20..... | 14,20..... | 16,20..... | 18,20..... | 20,20..... | 22,40..... | 26,40 |
| b..... | 16,00..... | 18,00..... | 22,00..... | 26,00..... | 30,00..... | 34,00..... | 38,00..... | 42,00..... | 46,00..... | 54,00 |
| h..... | 3,50..... | 4,00..... | 5,50..... | 7,00..... | 8,00..... | 9,00..... | 10,00..... | 12,00..... | 13,00..... | 15,00 |
| S..... | 8,00..... | 10,00..... | 13,00..... | 17,00..... | 19,00..... | 22,00..... | 24,00..... | 27,00..... | 30,00..... | 36,00 |
| e..... | 8,87..... | 11,05..... | 14,38..... | 18,90..... | 21,10..... | 24,49..... | 26,75..... | 30,14..... | 33,53..... | 39,98 |
| c..... | 0,20..... | 0,30..... | 0,40..... | 0,40..... | 0,40..... | 0,40..... | 0,40..... | 0,40..... | 0,40..... | 0,50 |

| | |
|---|--------------|
| | kg/1000 st. |
| L | kg/1000 pces |

| | | |
|----------|-----------|---|
| 30..... | 5,64..... | 8,06 |
| 35..... | 6,42..... | 9,13.....18,20 |
| 40..... | 7,20..... | 10,20.....20,70.....35,00 |
| 45..... | 7,98..... | 11,30.....22,20.....38,00.....53,60 |
| 50..... | 8,76..... | 12,30.....24,20.....41,10.....58,10.....82,20 |
| 55..... | | 13,40.....25,80.....43,80.....62,60.....88,30.....115,00 |
| 60..... | | 14,40.....27,80.....46,90.....67,00.....94,30.....123,00.....161,00 |
| 65..... | | 29,80.....50,00.....70,30.....100,00.....131,00.....171,00.....219,00 |
| 70..... | | 31,80.....53,10.....74,70.....106,00.....139,00.....181,00.....231,00 |
| 75..... | | 33,70.....56,20.....79,10.....112,00.....147,00.....191,00.....243,00.....364,00 |
| 80..... | | 35,70.....62,30.....83,60.....118,00.....155,00.....201,00.....255,00.....382,00 |
| 90..... | | 39,60.....68,50.....92,40.....128,00.....171,00.....220,00.....279,00.....428,00 |
| 100..... | | 43,60.....77,70.....100,00.....140,00.....186,00.....240,00.....303,00.....464,00 |
| 110..... | | 109,00.....152,00.....202,00.....260,00.....327,00.....500,00 |
| 120..... | | 118,00.....165,00.....218,00.....280,00.....351,00.....535,00 |

All models, types, values, rates, dimensions, a.s.o. are subject to change, without notice

10



ZESKANTTAPBOUTEN MET VOLLE DRAAD
VIS À TÊTE HEXAGONALE AVEC FILET COMPLET
 SECHSKANTSCHRAUBEN MIT GEWINDE ANNÄHREND BIS KOPF
HEXAGON HEADED SETSCREW

DIN 933
DIN 933
 DIN 933
DIN 933

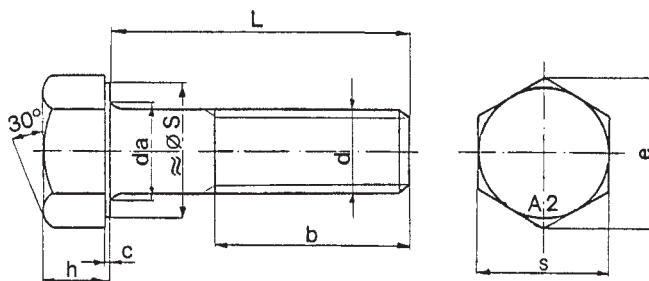

| | | |
|--------------|-------------------|--------------------|
| AISI | 304 | 316 |
| W.Nr. | 1.4301(A2) | 1.4401 (A4) |

| | | | | | | | | | | | | |
|---------|------|------|------|-------|-------|-------|-------|-------|-------|-------|-------|-------|
| d..... | M3 | M4 | M5 | M6 | M8 | M10 | M12 | M14 | M16 | M18 | M20 | M24 |
| da..... | 3,60 | 4,70 | 5,70 | 6,80 | 9,20 | 11,20 | 14,20 | 16,20 | 18,20 | 20,20 | 22,40 | 26,40 |
| h..... | 2,00 | 2,80 | 3,50 | 4,00 | 5,50 | 7,00 | 8,00 | 9,00 | 10,00 | 12,00 | 13,00 | 15,00 |
| s..... | 5,50 | 7,00 | 8,00 | 10,00 | 13,00 | 17,00 | 19,00 | 22,00 | 24,00 | 27,00 | 30,00 | 36,00 |
| e..... | 6,08 | 7,74 | 8,87 | 11,05 | 14,38 | 18,90 | 21,10 | 24,49 | 26,75 | 30,14 | 33,53 | 39,98 |
| c..... | 0,10 | 0,20 | 0,30 | 0,40 | 0,40 | 0,40 | 0,40 | 0,40 | 0,40 | 0,40 | 0,40 | 0,50 |

| | | |
|----------|-------|--------------|
| | | kg/1000 st. |
| L | | kg/1000 pces |
| 8..... | 0,655 | 1,49 |
| 10..... | 0,75 | 1,64 |
| 12..... | 0,84 | 1,80 |
| 16..... | 1,00 | 2,10 |
| 20..... | 1,18 | 2,41 |
| 25..... | 1,40 | 2,80 |
| 30..... | 3,19 | 5,11 |
| 35..... | 5,73 | 8,37 |
| 40..... | 6,35 | 9,23 |
| 45..... | 6,99 | 10,10 |
| 50..... | 7,59 | 11,00 |
| 55..... | 11,90 | 23,40 |
| 60..... | 12,70 | 25,00 |
| 65..... | 26,60 | 45,80 |
| 70..... | 28,20 | 48,30 |
| 75..... | 29,80 | 50,80 |
| 80..... | 31,40 | 53,30 |
| 90..... | 34,60 | 58,30 |
| 100..... | 37,70 | 63,30 |

All models, types, values, rates, dimensions, a.s.o. are subject to change, without notice

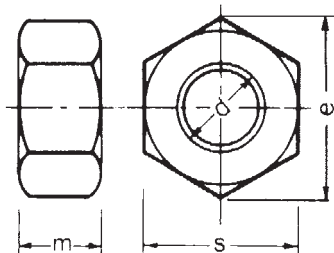

| AISI | 304 | 316 |
|-------|------------|-------------|
| W.Nr. | 1.4301(A2) | 1.4401 (A4) |

| d | m | S | e | kg/1000 st. kg/1000 pces |
|-----|-------|-------|-------|-----------------------------|
| M3 | 2,40 | 5,50 | 6,08 | 0,384 |
| M4 | 3,20 | 7,00 | 7,74 | 0,812 |
| M5 | 4,00 | 8,00 | 8,87 | 1,23 |
| M6 | 5,00 | 10,00 | 11,05 | 2,50 |
| M8 | 6,50 | 13,00 | 14,38 | 5,20 |
| M10 | 8,00 | 17,00 | 18,90 | 11,60 |
| M12 | 10,00 | 19,00 | 21,10 | 17,30 |
| M14 | 11,00 | 22,00 | 24,49 | 25,00 |
| M16 | 13,00 | 24,00 | 26,75 | 33,30 |
| M18 | 15,00 | 27,00 | 30,14 | 49,40 |
| M20 | 16,00 | 30,00 | 33,53 | 64,40 |
| M24 | 19,00 | 36,00 | 39,98 | 110,00 |
| M27 | 22,00 | 41,00 | 45,63 | 165,00 |
| M30 | 24,00 | 46,00 | 51,28 | 223,00 |

All models, types, values, rates, dimensions, a.s.o. are subject to change, without notice

10

VERZONKEN KOPSCHROEF MET VOLLE DRAAD
VIS À TÊTE FRAISÉE AVEC FILET COMPLET
 SENKSCHRAUBEN, KOPF MIT SCHLITZ
SLOTTED COUNTERSUNK HEADED MACHINESCREW

DIN 963
DIN 963
 DIN 963
DIN 963

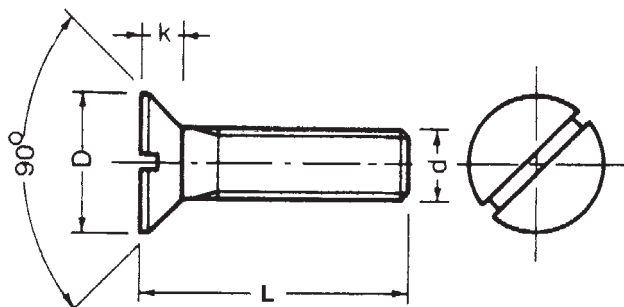

| | | |
|--------------|-------------------|--------------------|
| AISI | 304 | 316 |
| W.Nr. | 1.4301(A2) | 1.4401 (A4) |

| | | | | | | | | | | |
|--------|-----------|-----------|-----------|-----------|------------|------------|------------|------------|------------|-------|
| d..... | M2..... | M3..... | M4..... | M5..... | M6..... | M8..... | M10..... | M12..... | M16..... | M20 |
| D..... | 3,80..... | 5,60..... | 7,50..... | 9,20..... | 11,00..... | 14,50..... | 18,00..... | 22,00..... | 29,00..... | 36,00 |
| K..... | 1,20..... | 1,65..... | 2,20..... | 2,50..... | 3,00..... | 4,00..... | 5,00..... | 6,00..... | 8,00..... | 10,00 |

| L | kg/1000 st. | | | | | | | | | |
|----------|--------------|------------|------------|------------|------------|------------|-------------|-------------|--------|--|
| | kg/1000 pces | | | | | | | | | |
| 6..... | 0,156..... | 0,379..... | 0,754..... | 1,21 | | | | | | |
| 8..... | 0,193..... | 0,467..... | 0,910..... | 1,45..... | 2,19 | | | | | |
| 10..... | 0,231..... | 0,555..... | 1,06..... | 1,70..... | 2,54..... | 5,03 | | | | |
| 12..... | 0,268..... | 0,643..... | 1,22..... | 1,95..... | 2,89..... | 5,67..... | 9,59 | | | |
| 16..... | 0,343..... | 0,820..... | 1,53..... | 2,44..... | 3,60..... | 6,94..... | 11,60 | | | |
| 20..... | 0,996..... | 1,84..... | 2,94..... | 4,31..... | 8,21..... | 13,60..... | 20,80 | | | |
| 25..... | 1,22..... | 2,22..... | 3,55..... | 5,19..... | 9,79..... | 16,10..... | 24,40..... | 47,70 | | |
| 30..... | 1,44..... | 2,61..... | 4,16..... | 6,08..... | 11,40..... | 18,60..... | 28,10..... | 54,40..... | 90,50 | |
| 35..... | 1,70..... | 3,00..... | 4,65..... | 6,96..... | 13,00..... | 21,10..... | 31,70..... | 61,10..... | 101,00 | |
| 40..... | 2,00..... | 3,38..... | 5,40..... | 7,84..... | 14,60..... | 23,60..... | 35,30..... | 67,80..... | 111,00 | |
| 45..... | 2,30..... | 3,80..... | 6,02..... | 8,73..... | 16,20..... | 26,10..... | 39,00..... | 74,50..... | 122,00 | |
| 50..... | 2,70..... | 4,20..... | 6,65..... | 9,61..... | 17,80..... | 28,60..... | 42,60..... | 81,10..... | 132,00 | |
| 60..... | 3,20..... | 5,00..... | 7,35..... | 10,60..... | 20,80..... | 33,70..... | 49,80..... | 94,40..... | 153,00 | |
| 70..... | 3,90..... | 6,00..... | 8,85..... | 14,60..... | 23,80..... | 38,10..... | 57,10..... | 108,00..... | 174,00 | |
| 80..... | 7,00..... | 10,35..... | 16,60..... | 26,80..... | 43,10..... | 64,40..... | 121,00..... | 195,00 | | |
| 90..... | 11,90..... | 18,60..... | 29,80..... | 48,10..... | | | | 134,00..... | 216,00 | |
| 100..... | 20,60..... | | | | | | | 148,00..... | 237,00 | |

All models, types, values, rates, dimensions, a.s.o. are subject to change, without notice

DRAADSTANG
TIGE FILETEE
 GEWINDESTANGEN
FULL THREADED ROD

LENGTE 1 METER
LONGUEUR 1 METRE
 LÄNGE 1 METER
LENGTH 1 METER

DIN 975
DIN 975
 DIN 975
DIN 975

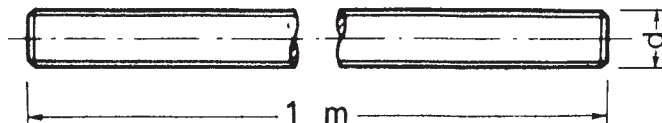

| AISI | 304 | 316 |
|-------|------------|-------------|
| W.Nr. | 1.4301(A2) | 1.4401 (A4) |

| d | M 2 | M 3 | M 4 | M 5 | M 6 | M 7 | M 8 | M 10 |
|--------------|-------|-----|-----|-----|-----|-----|-----|------|
| kg/1000 st. | | | | | | | | |
| kg/1000 pces | 18,70 | 44 | 78 | 124 | 177 | 248 | 319 | 500 |

| d | M 12 | M 14 | M 16 | M 18 | M 20 | M 22 | M 24 | M 27 |
|--------------|------|------|-------|-------|-------|-------|-------|-------|
| kg/1000 st. | | | | | | | | |
| kg/1000 pces | 725 | 970 | 1.330 | 1.650 | 2.080 | 2.540 | 3.000 | 3.850 |

| d | M 30 | M 33 | M 36 | M 39 | M 42 | M 45 | M 48 | M 52 |
|---------------|-------|-------|-------|-------|-------|--------|--------|--------|
| kg./1000 st. | | | | | | | | |
| kg./1000 pces | 4.750 | 5.900 | 6.900 | 8.200 | 9.400 | 11.000 | 12.400 | 14.700 |

All models, types, values, rates, dimensions, a.s.o. are subject to change, without notice

10

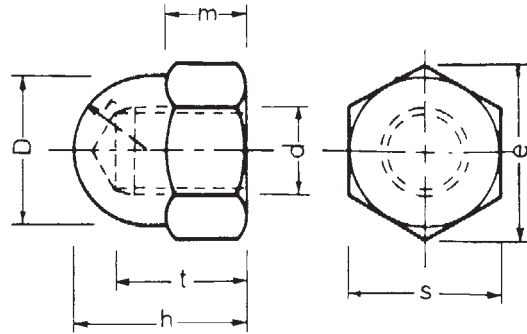

| AISI | 304 | 316 |
|-------|------------|-------------|
| W.Nr. | 1.4301(A2) | 1.4401 (A4) |

| d | D | h | t | m | s | e | kg/100 st. kg/1000 pces |
|-----|-------|-------|-------|-------|-------|-------|----------------------------|
| M4 | 6,50 | 8,00 | 5,50 | 3,20 | 7,00 | 7,74 | 2,00 |
| M5 | 7,50 | 10,00 | 7,50 | 4,00 | 8,00 | 8,87 | 3,00 |
| M6 | 9,50 | 12,00 | 8,00 | 5,00 | 10,00 | 11,05 | 4,66 |
| M8 | 13,00 | 15,00 | 11,00 | 6,50 | 13,00 | 14,38 | 11,00 |
| M10 | 16,00 | 18,00 | 13,00 | 8,00 | 17,00 | 18,90 | 20,10 |
| M12 | 18,00 | 22,00 | 16,00 | 10,00 | 19,00 | 21,10 | 28,30 |
| M14 | 21,00 | 25,00 | 18,00 | 11,00 | 22,00 | 24,49 | 40,00 |
| M16 | 23,00 | 28,00 | 21,00 | 13,00 | 24,00 | 26,75 | 54,30 |
| M18 | 26,00 | 32,00 | 25,00 | 15,00 | 27,00 | 30,14 | 95,00 |
| M20 | 28,00 | 34,00 | 26,00 | 16,00 | 30,00 | 33,53 | 104,00 |
| M22 | 31,00 | 39,00 | 29,00 | 18,00 | 32,00 | 35,72 | 129,00 |
| M24 | 34,00 | 42,00 | 31,00 | 19,00 | 36,00 | 39,98 | 216,00 |
| M27 | 38,00 | 48,00 | 33,00 | 25,00 | 41,00 | 45,51 | |
| M30 | 42,00 | 50,00 | 36,00 | 25,00 | 46,00 | 51,06 | |

All models, types, values, rates, dimensions, a.s.o. are subject to change, without notice

You talk stainless ... talk to us !

