



**SUNCOMBE**  
CIP & PROCESS ENGINEERS

**MobileCIP™**



**Gillain & Co**

HYGIENIC EQUIPMENT FOR FOOD & LIFE SCIENCES

## About Us

Suncombe Ltd supply Cleaning and hygienic processing technology for the Bio-Pharma, Medical, Food and other critical hygiene industries. From CIP to PartsWashers, we are uniquely capable of offering you a complete washing and processing solution.

Formed in 1961, we have a tremendous amount of experience in-house and provide a high level of technical and engineering expertise. Our completed projects range from stand-alone systems to complete processing solutions. Our products are built to a high quality and encompass all relevant legislation, guidelines, testing, documentation, quality assurance and traceability requirements.

## MobileCIP™ Introduction

The MobileCIP™ is a Total Loss Cleaning In Place system supplied worldwide to the BioPharm, Healthcare, Cosmetics, Personal Care, Food, Dairy, Beverage and other Processing Industries. Designed and developed to be mobile to allow the entire system to be moved to its point of use. Manual or automatically operated, the systems can be used for cleaning Tanks, Vessels, Vats, Fermenters, Mixers, Processors, Pipework, Valves, Isolators, Mills, Coaters, Filters, Pumps, Dryers and Fillers.

## Lean Technology

Adopting LEAN principles, all Suncombe products are developed to ensure they minimise utilities and time, whilst ensuring the safety of the operators and the efficiency of the cleaning. Utilising innovative fluid handling techniques, they incorporate a combination of traditional and new technologies to provide an environmentally friendly, low water and energy usage washing facility that is safe and ergonomic for the operators.



## CIP Liquid Storage

Incorporating a 316L Stainless steel sanitary CIP storage vessel for storing, batching and delivering CIP fluids. Complete with control and safety instrumentation.

## CIP Delivery

Incorporating a 316L Stainless steel variable speed pump the system can be tuned to your equipment, ensuring that the optimum CIP parameters are achieved every time whilst minimising liquid and energy usage and time.

## Detergent Dosing

One to four liquid dosing systems, which can be incorporated within any recipe step at any concentration, complete with dosing safeguards including low detergent confirmation and detergent dosed volume confirmation, as well as pump priming facilities.

## Automation

Suncombe offers four different control packages, CIPSuite1™ to CIPSuite4™, they all incorporate the optimum control for operation, providing a simple to use interface which incorporates advanced facilities.

## Validation/ Documentation

The lifecycle approach is adopted (DQ, FAT, SAT, IQ & OQ) with validation being key to every stage of the development process, including Factory Acceptance Testing (FAT), SAT and Qualification.

## Example Uses

- » Cleaning in Zoned Areas
- » Cleaning in Separated areas
- » Cleaning Development
- » Trials
- » Ideal for Periodic Cleaning
- » CIP Familiarisation

## Key Features

- 316L Stainless steel wetted parts .
- Sloping design and smooth, crevice-free construction
- EPDM, PTFE FDA-approved elastomers and tri-clamp connections
- Enclosed head orbital welding to EN287/15614
- 316/304 stainless steel non-wetted parts
- 200 litre storage tank included with double wall insulated construction to reduce electricity consumption and heat loss
- Atmospheric vents or heated vent filter options
- Optional additional storage tanks
- BioPharma Diaphragm valves
- Certified surface finishes to 0.4 ra and optionally electropolished
- Large hygienic variable speed delivery pump
- BioPharma instrumentation
- Fully self-draining including pump housing
- High power electrical liquid heating for fast heatup times
- One to four liquid dosing systems including dosing confirmation
- Fully adjustable cycle parameters including temperatures, pressures and times
- Available with Conductivity controllers for detergent concentration and pure water.
- CIPSuite™ Control Systems with a colour graphic operator interface for visualisation
- Password control
- Up to 100 Fully configurable recipes
- In built troubleshooting and diagnostic ability
- USB port for connections to desktop printer
- Optional desktop printer for printouts of operation
- Up to 3 x detergent dosing facilities
- Easy maintenance
- Final rinse recirculated or non-recirculated to eliminate possibility of cross-contamination between rinses.
- Two fixed and two swivel non-marking castors
- Can be fitted with stainless steel covers
- ATEX versions available for solvent use and/or aqueous use in zoned areas
- MobileCIP docking stations and thru wall panels available

## Support

The Suncombe Technical Support and Customer Care departments' obligation is to provide total customer support. This support starts at the proposal stage, continues throughout the contract and thereafter. A personal customer care agent will be assigned to you at quotation stage and will support you throughout. The department currently supports all of our clients over the last 50 years. Support includes advise and surveys, installation and commissioning, User training, call-out repairs and service contracts for preventative maintenance.

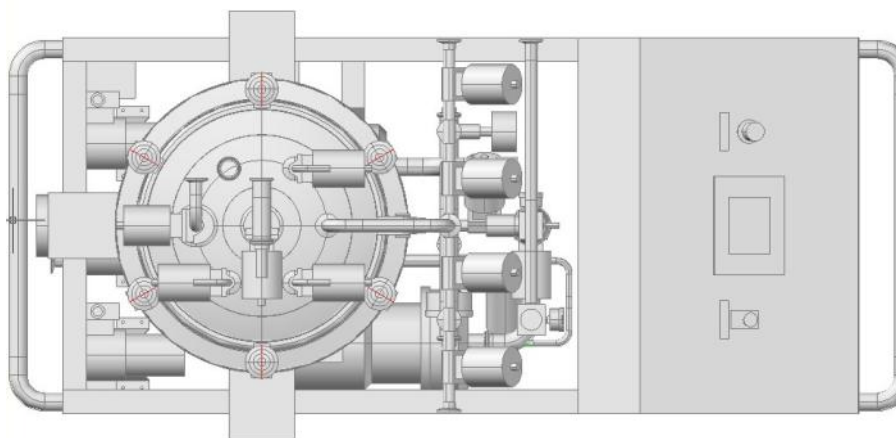
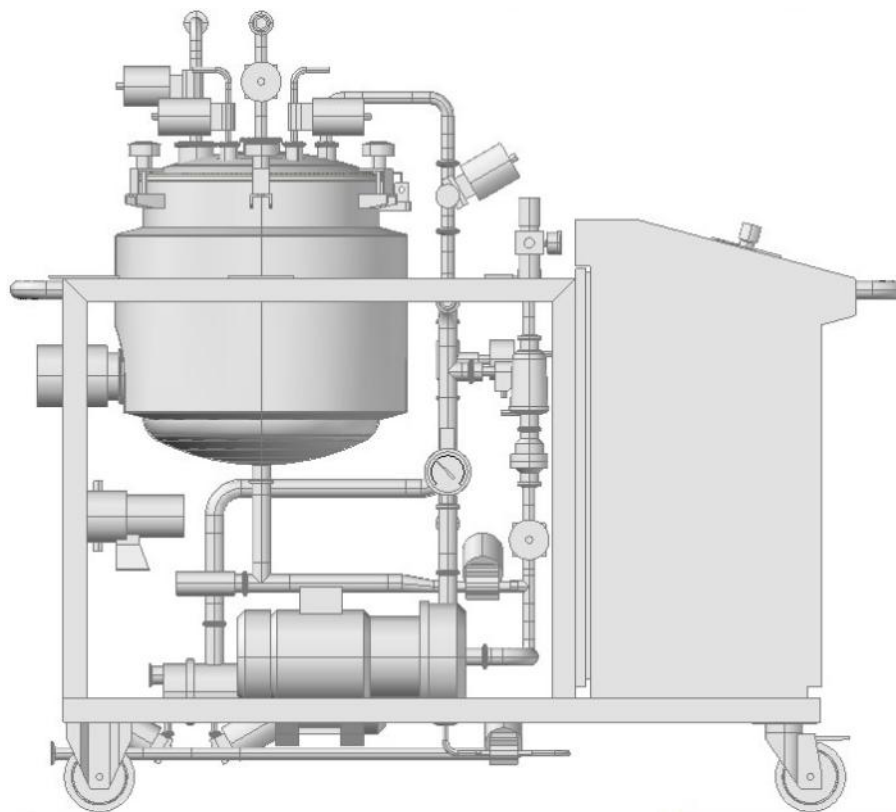

## Automation

**CIPSuite#1™** - Simple versatile automatic control system with 6 time changeable recipes.

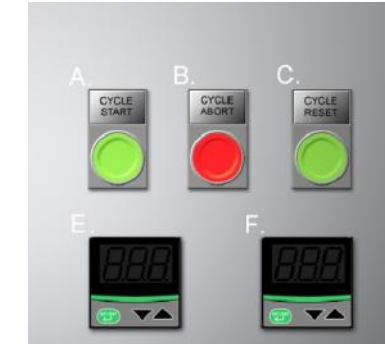

**CIPSuite#2™** - Automatic control system with 100 fully configurable recipes, time changeable recipes, I/O faceplates, Mimic diagrams, Printer, Profibus Communications Protocol, Repeatable automatic cycles, User control with passwords, In built troubleshooting and diagnostic ability.

## Control Panel

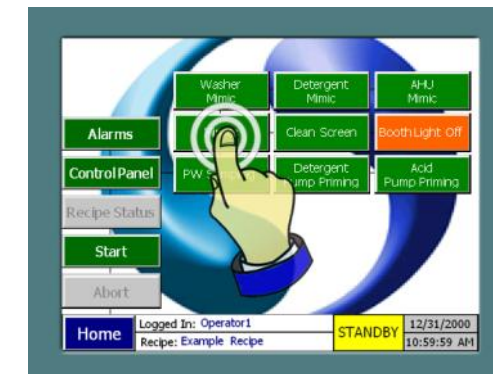

## Mimic

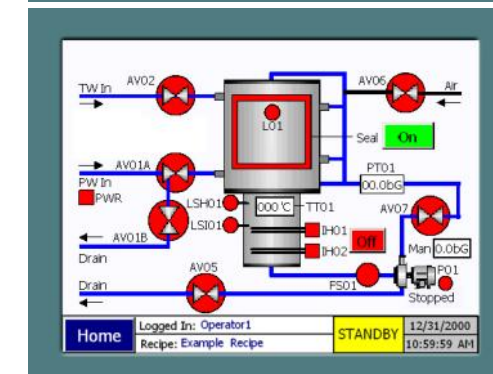

## Recipe Setup

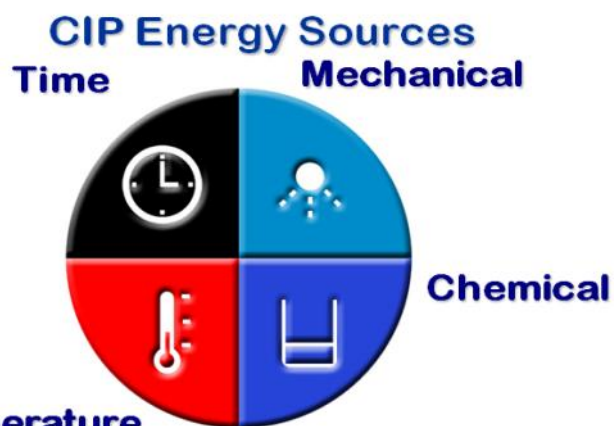

Temperature