

Alfa Laval CM Connect

Condition monitoring

Introduction

The ability to determine the current running condition of equipment and whether service or maintenance is necessary is paramount to keeping plant and processes running efficiently and cost effective. Having this overview whilst at your desk or on your mobile device without needing to collect data from the process floor increases plant safety.

The Alfa Laval CM Connect is a compact, easy to use, cloud-based gateway and vibration monitoring system which allows the user to connect and remotely monitor the condition and changes in running behaviour of rotating equipment. Providing users via built-in wireless cellular technology with easy, safe data, accessed remotely from a PC or handheld mobile device to enable them to optimise their process uptime, assist in maintenance scheduling and efficiency and reduce operating costs.

As a monitor and gateway the Alfa Laval CM Connect periodically measures the tri-axial vibration and the internal monitor temperature of the installed unit sending the data to the cloud for remote monitoring and analysis. In addition, it can be used as a gateway for up to 10 Alfa Laval CM's connected within Bluetooth range. Users can compare the current running status against the original baseline set-up of this equipment network and if pre-set warning and alarm levels are exceeded alerts can be sent via e-mail or SMS to selected recipients.

Advanced frequency analysis functions assist the user in detecting maintenance demanding equipment components in due time, so that maintenance can be carried out as a planned operation.

All data and alerts are stored in the cloud and can be accessed for easy record keeping and troubleshooting.

In addition, unique identification can provide the user with service data of the equipment and contacts of service partners to ease the maintenance process, ensuring asset value, total cost of ownership and process continuity.

Application

Designed for hygienic applications, the Alfa Laval CM Connect is suited for use in the dairy, food, beverage, personal care and pharma/biotech industries. In particular the applications where the customer is focused on continuous processing



manufacturing where the preventative maintenance attributes can be fully appreciated.

Benefits

- Safe, remote data collection
- Intuitive user interface
- Continuous trend data to assist in early detection of process instability, maintenance scheduling & failure analysis
- Overview of total run time to assist in periodic maintenance scheduling and spare part logistics
- Prioritize actions for assets dependant on current running condition

Standard design

The Alfa Laval CM Connect is a PA12 plastic hermetically sealed monitoring device suitable for use in a hygienic environment with washdown. It can be mounted on a wall as a gateway device for a network of Alfa Laval CM's or used as a gateway and monitor if attached to the rotating equipment. A stainless-steel adaptor will be supplied to retro-fit to existing and new Alfa Laval equipment dependent on product range, size and model.

Working principle

The Alfa Laval CM Connect with its' 4G LTE connectivity uses a 3 axis accelerometer and internal temperature sensor to collect and send data to the cloud for remote monitoring. In addition, a Bluetooth antenna enables connectivity of a network of 10 installed Alfa Laval CM's within Bluetooth range providing a complete overview of equipment in that process location. The data can be accessed via an intuitive, user-friendly dashboard on a PC, IOS or Android mobile device.

When a monitor senses some vibration it starts the running hours counter and monitors the tri-axial vibration and internal temperature of the unit at pre-set intervals determined by the user. This information is sent via cellular connectivity to the cloud for review or action.

The user can then utilise the dashboard to have a complete overview of the assets and their current running status. Selecting any of the assets the user can review vibration levels and Fast Fourier Transform (FFT) data to determine current trend condition against original benchmark values, and in the case of a warning or alarm mode, alerts can be sent via e-mail or SMS to selected recipients who can use the data for system root cause analysis.

In addition, the dashboard will relay, battery life of CM's, historical data for vibration and in unit temperature, current and total running hours, number of stop/starts and information on the unit under monitoring.

TECHNICAL DATA

General	
Plastic parts:	PA12
Steel parts:	1.4301 (AISI 304)
Size:	86 mm x 117 mm x 41 mm (3.4 x 4.6 x 1.6 inch)
Weight:	164 grams (5.8 oz)
Power requirements	
Power supply:	24 VDC, 7-15W
Wireless Communication	
Cellular data:	4G LTE with global frequencies support Sim card included
Bluetooth Low Energy:	5.0
Environment	
Operating temperature:	-30°C to 70°C (-22°F to 158°F)
Protection class (water ingress):	IP67 & NEMA4X
Operating parameters	
Sampling frequency:	standard 833 Hz. Up to 1.6 kHz
Temperature resolution:	1.5°C (3°F)
3 axis vibration:	0~4 g
Surface temperature:	up to 80°C (176°F)
Cloud connection:	Cellular data
Bluetooth range:	20 metres (65 Ft) line of sight
Compliances	
The Alfa Laval CM-Connect is in compliance to CE, UKCA, Reach, RoHS. For further compliances, please contact Alfa Laval.	
Warranty	
12 months from date of despatch.	

Dimensions (mm)

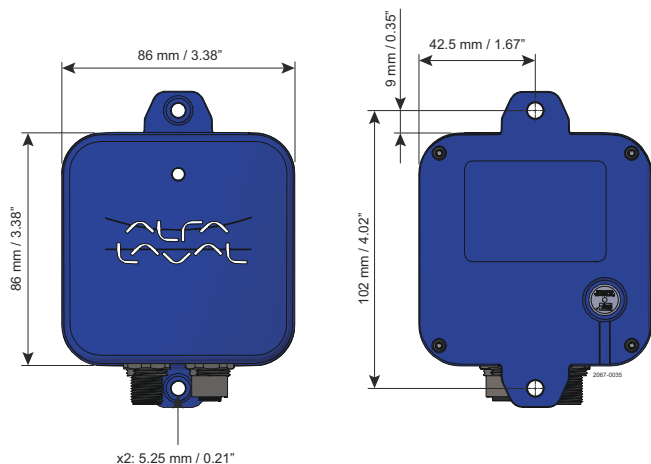

This document and its contents are subject to copyrights and other intellectual property rights owned by Alfa Laval Corporate AB. No part of this document may be copied, re-produced or transmitted in any form or by any means, or for any purpose, without Alfa Laval Corporate AB's prior express written permission. Information and services provided in this document are made as a benefit and service to the user, and no representations or warranties are made about the accuracy or suitability of this information and these services for any purpose. All rights are reserved.

200005829-2-EN-GB

© Alfa Laval Corporate AB

How to contact Alfa Laval

Up-to-date Alfa Laval contact details for all countries are always available on our website at www.alfalaval.com